

4

3

2

1

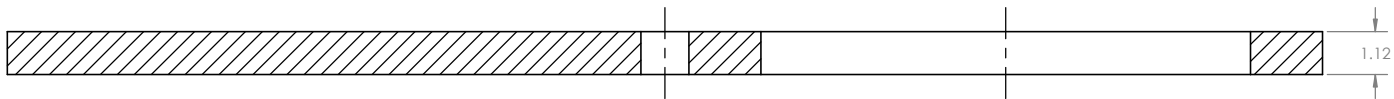
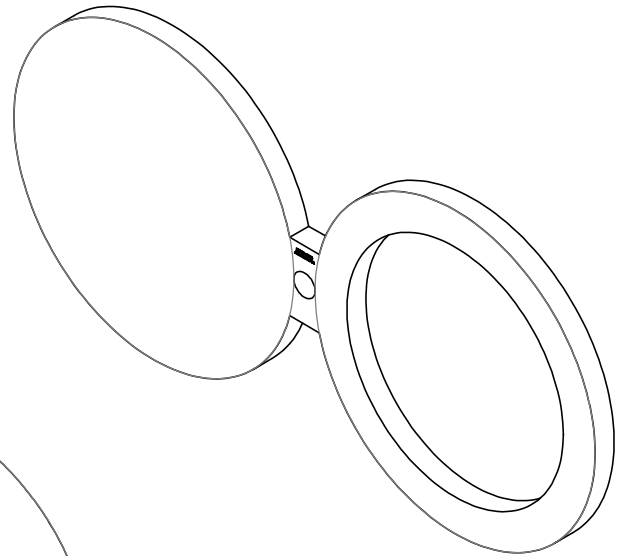
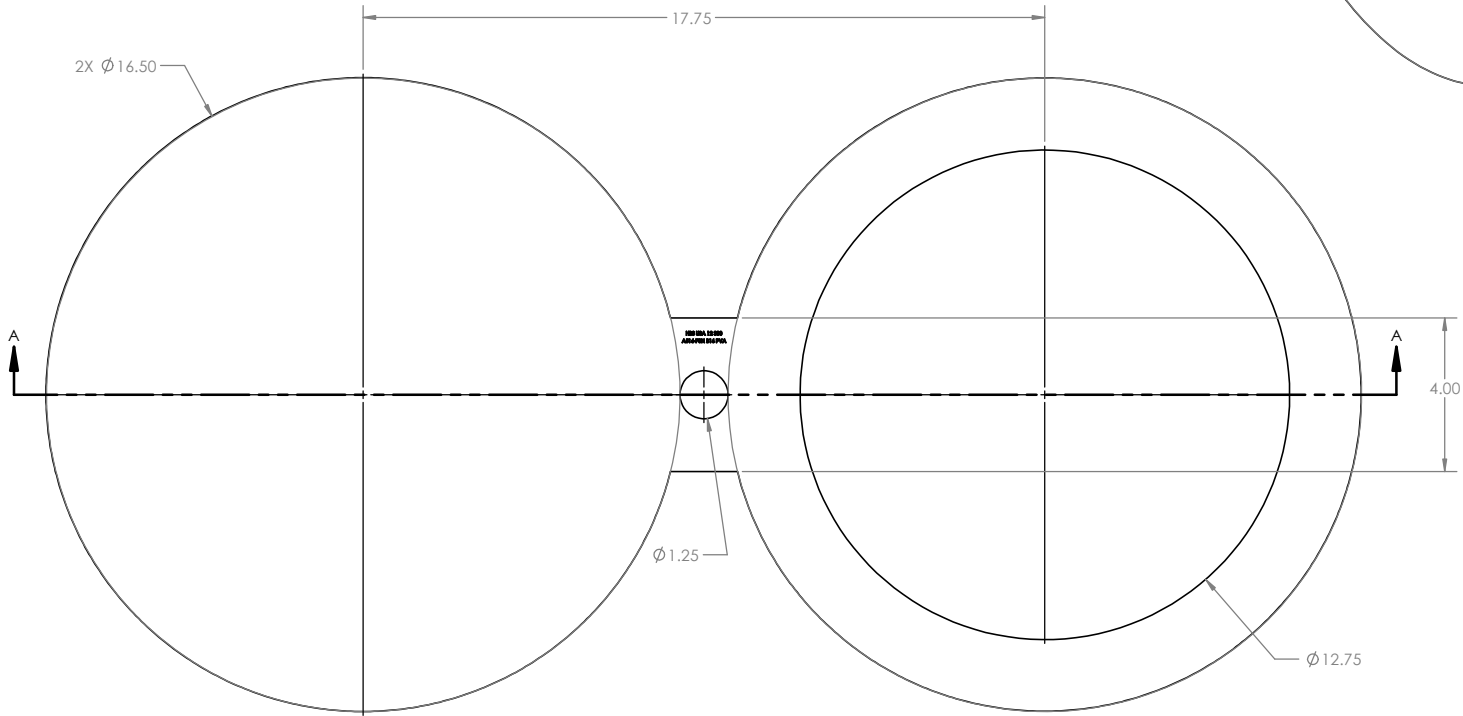

SECTION A-A

DO NOT SCALE PRINT		UNLESS OTHERWISE SPECIFIED: OUTSIDE DIAMETER: (+/-0.12) INSIDE DIAMETER: (+/-0.12) THICKNESS TOLERANCES (-ZERO +0.12) ALL UNITS IN INCHES OR POUNDS		HYDROBLIND -ISOLUTIONS
		SHEET 1 OF 1		
MATERIAL: CUSTOMER REQUESTED		DATE: 06/24/2020		DRAWING TITLE: 12 CL 300 FIGURE 8 BLIND
SCALE 1:2.5	SIZE C	DIMENSIONS & TOLERANCES TO BE IN ACCORDANCE WITH ASME B16.48	WEIGHT 95 lb	REV 00
		DRAWING NUMBER: 3SBT		

4

3

2

1